

ADCOM[®]
HIGH CURRENT
POWER AMPLIFIER
GFA-555II

THE FOLLOWING PRECAUTIONS AND SAFETY INSTRUCTIONS ARE REQUIREMENTS OF UL AND CSA SAFETY REGULATIONS

Warning: To reduce the risk of fire or electric shock, do not expose this unit to rain or moisture.

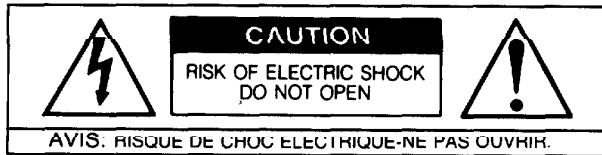

The graphic symbol of a lightning flash with an arrow point within a triangle signifies that there is dangerous voltage within the unit and it poses a hazard to anyone removing the cover to gain access to the interior of the unit. **Only qualified service personnel should make any such attempt.**



The graphic symbol of an exclamation point within an equilateral triangle warns a user of the device that it is necessary to refer to the instruction manual and its warnings for proper operation of the unit.



Do not place this unit on an unstable cart, stand, tripod, bracket, or table. The unit may fall, causing serious injury to a child or adult, and serious damage to the unit. Use only with a cart, stand, tripod, bracket, or table recommended by the manufacturer, or sold with the unit. Any mounting of the device should follow the manufacturer's instructions, and should use a mounting accessory recommended by the manufacturer.

Read all the safety and operating instructions before connecting or using this unit.

Retain this notice and the owner's manual for future reference.

All warnings on the unit and in its operating instructions should be adhered to.

All operating and use instructions should be followed.

Do not use this unit near water; for example, near a bathtub, washbowl, kitchen sink, laundry tub, in a wet basement, or near a swimming pool.

The unit should be installed so that its location or position does not interfere with its proper ventilation. For example, it should not be situated on a bed, sofa, rug, or similar surface that may block the ventilation openings; or placed in a built-in installation, such as bookcase or cabinet, that may impede the flow of air through its ventilation openings.

The unit should be situated away from heat sources such as radiators, heat registers, stoves, or other devices (including amplifiers) that produce heat.

The unit should be connected to a power-supply outlet only of the voltage and frequency marked on its rear panel.

The power-supply cord should be routed so that it is not likely to be walked on or pinched, especially near the plug, convenience receptacles, or where the cord exits from the unit.

Clean unit only as recommended in its instruction manual.

The power-supply cord of the unit should be unplugged from the wall outlet when it is to be unused for a long period of time.

Care should be taken so that objects do not fall, and liquids are not spilled, into the enclosure through any openings.

This unit should be serviced by qualified service personnel when:

- A. The power cord or the plug has been damaged; or
- B. Objects have fallen, or liquid has been spilled, into the unit; or
- C. The unit has been exposed to rain, or liquids of any kind; or
- D. The unit does not appear to operate normally, or exhibits a marked change in performance; or
- E. The device has been dropped, or the enclosure damaged.

**DO NOT ATTEMPT SERVICING OF THIS UNIT YOURSELF.
REFER SERVICING TO QUALIFIED SERVICE PERSONNEL.**

ATTENTION

POUR PREVENIR LES CHOCS ELECTRIQUES NE PAS UTILISER CETTE FICHE POLARISEE AVEC UN PROLONGATEUR, UNE PRISE DE COURANT OU UNE AUTRE SORTIE DE COURANT, SAUF SI LES LAMES PEUVENT ETRE INSEREES A FOND SANS EN LAISSER AUCUNE PARTIE A DECOUVERT.

CAUTION

TO PREVENT ELECTRIC SHOCK DO NOT USE THIS POLARIZED PLUG WITH AN EXTENSION CORD, RECEPTACLE OR OTHER OUTLET UNLESS THE BLADES CAN BE FULLY INSERTED TO PREVENT BLADE EXPOSURE.

CAUTION POWER LINES

Any outdoor antenna must be located away from all power lines.

OUTDOOR ANTENNA GROUNDING

If an outside antenna is connected to your tuner or tuner-preamplifier, be sure the antenna system is grounded so as to provide some protection against voltage surges and built-up static charges. Section 810 of the National Electrical Code, ANSI/NFPA No. 70-1964, provides information with respect to proper grounding of the mast and supporting structure, grounding of the lead-in wire to an antenna discharge unit, size of grounding conductors, location of antenna discharge unit, connection to grounding electrodes, and requirements for the grounding electrode.

- a. Use No.10 AWG (5.3 mm²) copper, No.8 AWG (8.4 mm²) aluminum, No.17 AWG (1.0 mm²) copper-clad steel or bronze wire, or larger, as a ground wire.
- b. Secure antenna lead-in and ground wires to house with stand-off insulators spaced from 4-6 feet (1.22-1.83 m) apart.
- c. Mount antenna discharge unit as close as possible to where lead-in enters house.
- d. Use jumper wire not smaller than No.6 AWG (13.3 mm²) copper, or the equivalent, when a separate antenna-grounding electrode is used. See NEC Section 810-21 (j).

EXAMPLE OF ANTENNA GROUNDING AS PER NATIONAL ELECTRICAL CODE INSTRUCTIONS CONTAINED IN ARTICLE 810 - RADIO AND TELEVISION EQUIPMENT.

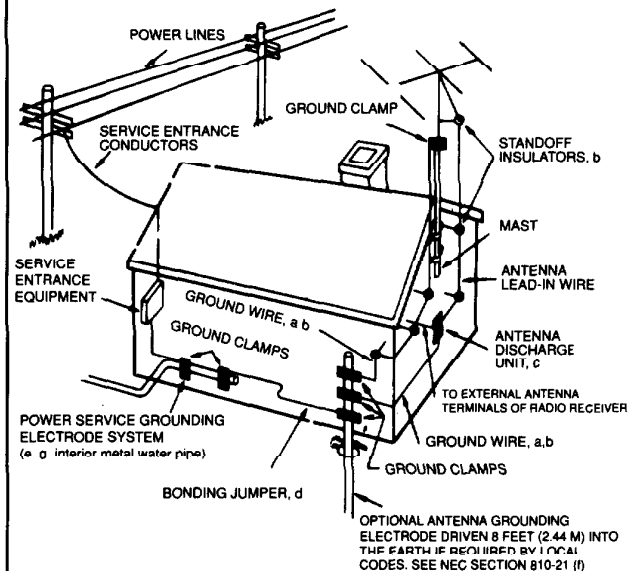

NOTE TO CATV SYSTEM INSTALLER

This reminder is provided to call the CATV system installer's attention to Article 820-22 of the National Electrical Code that provides guidelines for proper grounding and, in particular, specifies that the cable ground shall be connected to the grounding system of the building, as close to the point of cable entry as practical.

INTRODUCTION

Please read thoroughly these operating instructions for the GFA-555II before connecting or attempting to operate it. The installation and operation of the GFA-555II are described in the following pages. We sincerely hope you will value and enjoy the considerable attention we have given its design and construction. This manual has been written to help you understand the correct operation of the GFA-555II. Please read it carefully to fully comprehend all its features and functions and thereby derive maximum performance from its use in your system. It is a good idea to keep this manual handy for future reference.

PREFACE

The GFA-555II is a completely upgraded version of the famous GFA-555. While it retains the conservative power-output rating of the original GFA-555, its redesign significantly reduces distortion in the amplifier when driving difficult loudspeaker loads.

WARNING

The GFA-555II is a very powerful amplifier capable of delivering very large peaks into low impedances, exceeding 80 amperes per channel. Therefore, be certain to exercise **extreme** caution when making connections to and from the amplifier. Always make certain that the amplifier is **disconnected** from the AC outlet, and its large filter capacitors are **discharged**. Please note that the power supply capacitors can take as long as **five minutes** to discharge. Failure to observe this precaution may result in damage to the loudspeakers and/or blowing of the amplifier's **DC RAIL FUSES**, conditions which are **NOT** covered by the Warranty.

The GFA-555II amplifier can drive a very broad range of loudspeakers, including those with very low impedances, at sustained high-power levels, even when the impedances are highly reactive. Great care was taken to insure that distortion in the amplifier would remain extremely low, particularly when driving these highly reactive loads in which the phase angles of the voltage and the current are substantially different. A little known fact is that amplifiers which measure extremely well on the test bench into a resistive load may not develop the same amount of power into a loudspeaker. Depending on the amplifier's design, sometimes as little as one third of the power which the amplifier develops into a resistor is delivered to a speaker load. Also, the distortion level measured when the amplifier is driving a resistive load is degraded, in some cases quite substantially, when driving the loudspeaker. It is, however, very difficult to measure the performance of an amplifier into a loudspeaker. One reason why this information is not widely known is because during such high-power tests, destruction of the loudspeaker is often the result. In order to determine the performance of the GFA-555II, ADCOM developed a "computer model" of a "difficult" loudspeaker load. A computer model "mimics" the reactance of the very difficult speaker and duplicates the actual phase angles of the voltage and current throughout the entire audio range. In this manner, high-power testing of amplifier parameters could be undertaken without repetitive destruction of the loudspeaker load.

To achieve the above, eight sets of specially selected TO-3-type, metal-cased bipolar output transistors are used in the GFA-555II in a triple-Darlington configuration of its driver and output stages. The safe operating area of these transistors, along with their circuit topology, insures very efficient power delivery to reactive loads, regardless of the phase angle of voltage and current. In addition, no protection or current-limiting circuitry is used in the GFA-555II which could degrade the signal.

Electronic protection, or current-limiting circuitry, would impede the delivery of large amounts of current (power) to low-impedance, highly reactive loads, thereby constricting dynamics and deteriorating sonically the performance of the amplifier. Therefore, only fuses on the DC rails are used for protection.

The power supply in the GFA-555II has enormous reserve power capability with an extremely large transformer feeding a storage bank of 60,000uF of filter capacitance. The transformer itself was designed for extremely good regulation, insuring stable voltages regardless of the power demands from the amplifier. Its higher efficiency was insured by using a toroidal design. Additionally, thermal and dynamic tracking of the bias for the triple-Darlington driver and output stages is provided to insure that the amplifier operates in its optimal range regardless of the length of time and the level of operation.

The GFA-555II's circuitry is direct-coupled internally to minimize the sonic deterioration which capacitors, when used between stages of amplification, can cause. As a result, the GFA-555II can amplify DC and has no limit as to low-frequency or peak-bass energy delivery. In particular, the driver stages are designed to provide all the current required by the output devices without limiting, compressing, or otherwise distorting the signal coming into the power amplifier.

All internal point-to-point wiring is OFC and the highest-grade parts, consistent with their application and voltage requirement, have been used in its construction. In especially critical circuits, the finest quality film capacitors have been used. Among its other design improvements are the following:

- Larger potted transformer provides better overall regulation for driving lower impedances at high power levels; also provides greater peak-current capability into loudspeaker loads.
- No electrolytic capacitors in the low-frequency signal path or feedback-loop path. Only precision non-polarized capacitors are used.
- Addition of a servo circuit minimizes DC-offset voltage at the loudspeaker outputs; this insures that there is no woofer "biasing" with attendant low-frequency distortion.
- Larger heatsinks for each channel for greater heat dissipation and better temperature and dynamic bias tracking. Greater thermal stability is thereby insured.
- More cooling vents on top cover and chassis for greater cooling efficiency and cooler operation into lower impedances.
- High-quality, gold-plated brass RCA input jacks with Teflon insulators.
- Thermal overload indicator LED on front panel.

IMPORTANT NOTICE

ADCOM PROTECTION PLAN (U.S.A. ONLY)

ADCOM offers the enclosed valuable Limited Warranty. Please read the details on the Warranty Card carefully to understand the extent of the protection offered by the Warranty, its reasonable limitations, and what you should do in order to obtain its benefits.

Be sure to verify that the serial number printed on the rear panel matches the serial number on the outer carton. If any number is altered or missing, or if the ADCOM Warranty Card is not included in the carton, you should notify us immediately in order to insure that you have received a genuine ADCOM product which has not been opened, mishandled or tampered with in any way.

UNPACKING

Before your GFA-555II left our plant, it was carefully inspected for physical imperfections and tested for all electrical performance parameters as a routine part of ADCOM's systematic Quality Control. This, along with full operational and mechanical testing, should insure a product flawless in both appearance and performance. After you have unpacked the GFA-555II, inspect it for physical damage. Save the shipping carton and all internal packing materials, as they are intended to reduce to a minimum the possibility of transportation damage, should the amplifier ever need to be shipped again. In the unlikely event damage has occurred, notify your dealer immediately and request the name of the carrier so that a written claim to cover shipping damages can be initiated.

THE RIGHT TO A CLAIM AGAINST A PUBLIC CARRIER CAN BE FORFEITED IF THE CARRIER IS NOT NOTIFIED PROMPTLY IN WRITING AND IF THE SHIPPING CARTON AND PACKING MATERIALS ARE NOT AVAILABLE FOR INSPECTION BY THE CARRIER. SAVE ALL PACKING MATERIALS UNTIL THE CLAIM HAS BEEN SETTLED.

INSTALLING THE GFA-555II

The GFA-555II is equipped with large heatsinks to dissipate the heat generated by the output power transistors. Although during normal home operation the heatsinks will become just warm to the touch, there are instances during high-level playback into low impedances which will cause the heatsinks to become much warmer than normal. Therefore, adequate air circulation must be made available to insure proper heat dissipation from the heatsinks. You will insure the amplifier's long-term, trouble-free operation if you keep it away from external sources of heat, such as radiators or hot-air ducts, and provide reasonable ventilation. The GFA-555II should never be placed with other heat-producing components in a cabinet or enclosure lacking free air flow. You should also provide adequate space around the amplifier to insure good air circulation.

The top, bottom and side panels of the amplifier have been provided with slots to allow necessary cooling of the internal components of the amplifier. You should insure that these slots are not obstructed in any way.

We advise that you refrain from stacking other components on top of the GFA-555II. Not only will the heat generated by the amplifier affect the performance of equipment stacked on top of the GFA-555II, but the free flow of air through the ventilating slots provided in the chassis of the amplifier may be partially obstructed. If you require that the GFA-555II be mounted in an enclosed cabinet, it is recommended that the rear panel of the cabinet be provided with vents or slots at the bottom and top to allow air to circulate freely through the cabinet.

If you observe these recommendations, the GFA-555II will perform quite reliably in any reasonable environment. You should also pay attention to such routine considerations as protection from excessive dust and moisture. Occasional vacuuming of accumulated dust on the surfaces of the chassis, panels and heatsinks should be all that is required.

FAN OPTION

For those special applications in which the GFA-555II will be used in very demanding installations (driving highly reactive, very low-impedance loads, at high-average power levels), it may be necessary to use the FAN OPTION which is available as an extra-cost accessory. The FAN OPTION consists of a top plate with a continuously variable cooling fan mounted on it (see section **THERMAL OVERLOAD** following) which will increase the air flow through the amplifier by several orders of magnitude. It can be easily installed by your ADCOM Dealer or ADCOM Authorized Service Station.

For use in professional installations, the GFA-555II may be mounted in a standard 19-inch rack using the optional RM-7 rack-mount adaptors available through ADCOM dealers. If the GFA-555II is to be mounted on a rack, along with other components which are interconnected to the GFA-555II, the amplifier's chassis must be **insulated** from the metal-rack rails to prevent ground loops, especially if the rack is grounded to "earth", and to avoid defeating the audio grounding scheme of the power amplifier (the audio-input grounds are isolated from and above the chassis ground). Please consult the instruction sheet packed with the optional rack-mount adaptors for more information.

CONNECTING THE GFA-555II

The optimal performance of the GFA-555II will ultimately depend on the care with which you perform the connections to the amplifier, the preamplifier and the loudspeakers. All the input- and output-signal connections should be made only with high-quality, low-loss cables following the recommendations made in the individual sections below. Please refer to the rear-panel diagram to identify all the connections and their locations.

NOTE

WHENEVER CONNECTIONS TO OR FROM THE GFA-555II ARE BEING MADE, BE CERTAIN THAT THE POWER ⑥ SWITCH ON THE AMPLIFIER IS IN ITS OFF POSITION, THE AC LINE CORD ④ OF THE AMPLIFIER IS DISCONNECTED FROM THE AC WALL OUTLET AND THAT ALL ASSOCIATED COMPONENTS ARE TURNED OFF.

RIGHT/LEFT INPUT ①

The audio inputs to the GFA-555II are through two high-quality, gold-plated brass RCA jacks using Teflon insulation to minimize high-frequency losses, noise, etc. They will accept standard RCA-type plugs, one for each channel, LEFT and RIGHT, usually supplied at the ends of interconnecting cables. To insure that the performance designed into the GFA-555II is preserved, you should use the highest quality plugs and cable as are feasible. There are many cables which are designed specifically for these applications and your ADCOM dealer can be of help in selecting the best cable for your application. Whatever cable you finally select, it should have low capacitance. This is particularly important if you use a long run between the preamplifier and the amplifier or if your preamplifier has a high output impedance. Generally speaking, a cable with a capacitance of around **100pF** will work well.

The load impedance which the GFA-555II inputs present to the source preamplifier is 100,000 ohms. This load impedance results in minimal amplifier noise and is more than adequate for use with any associated source component regardless of its output impedance.

To preserve the correct stereophonic effects, please be certain to connect the left output of the preamplifier to the RCA jack on the GFA-555II labelled LEFT INPUT and the right output of the preamplifier section to the RCA jack labelled RIGHT INPUT.

RIGHT/LEFT STEREO SPEAKER OUTPUTS ②

The GFA-555II's connections to the loudspeakers are made through high-grade 5-way, gold-plated brass binding-post terminals ② located on the rear panel. These terminals will accommodate either bare wire, tinned wire, terminal pins, spade lugs, or "banana plugs", both single and dual. The output terminals are color-coded RED and BLACK to indicate polarity. To insure correct stereo phasing, you must connect the RED output terminal (labelled "+") to the loudspeaker input terminal color-coded RED (or labelled POSITIVE, "+", POS, 8 OHMS or 4 OHMS). The BLACK binding post terminal on the amplifier (labelled "-") should be connected to the BLACK loudspeaker terminal (or labelled NEG, "-", C, COM, COMMON, G, or GROUND).

NOTE

The GFA-555II is polarity correct; that is, it does **not** invert "phase". Any positive-going signal at its inputs will appear as a positive-going signal at its outputs.

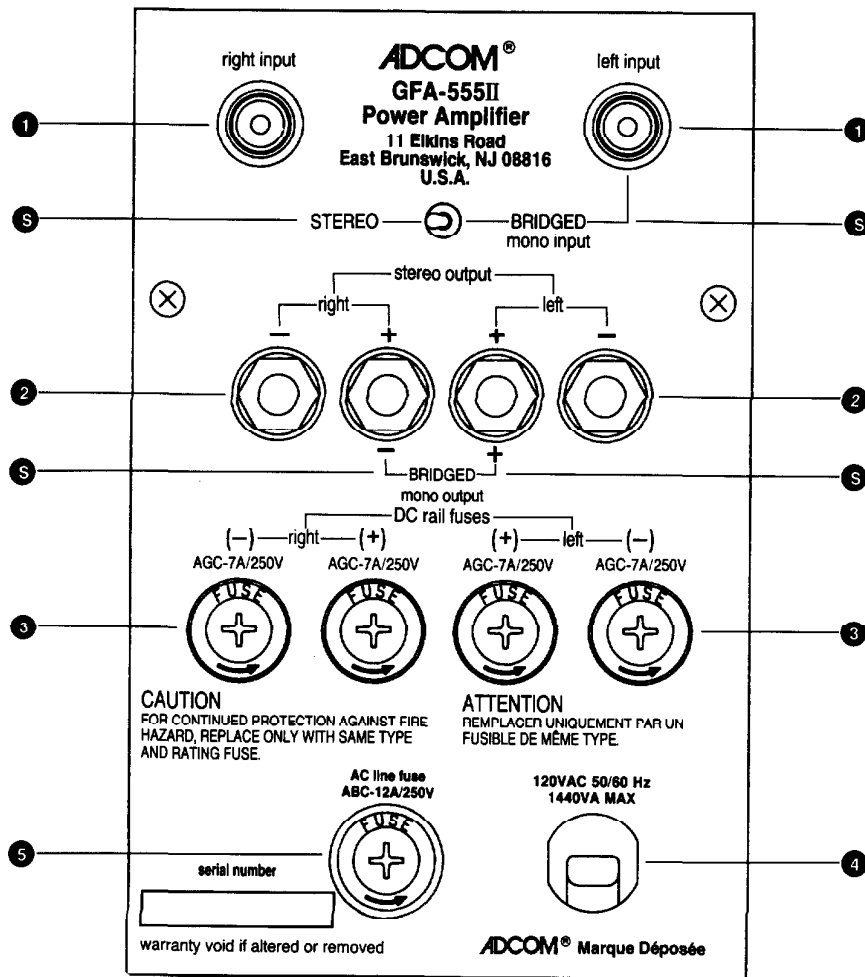

GFA-555II Rear Panel Diagram

The RIGHT STEREO OUTPUT should be connected to the right-channel loudspeaker, as you face the pair of loudspeakers, and the LEFT STEREO OUTPUT to the left-channel loudspeaker.

Be certain, when the GFA-555II is used in its stereophonic mode, the STEREO/BRIDGED MONO INPUT ⑤ switch is in the STEREO position. Otherwise, the amplifier will not operate in the stereo mode. You will amplify only the left channel through both outputs of the amplifier. For further clarification, please refer to the section STEREO/BRIDGED MONO INPUT/OUTPUT ⑤.

In order to insure that connections to the loudspeakers are correct, you must be able to identify each wire conductor of the loudspeaker cables at both ends of the cables. This is relatively easy to do since most loudspeaker cables consist of two parallel, stranded conductors in a flexible insulation, with a coding system for wire identification. Sometimes there is a colored "tracer" wrapped around one of the conductors; some cords have one of the conductors colored silver and the other copper; some have a "ridge" molded on the insulation on one of the conductors, while others are marked with a "+" and/or "-". Your ADCOM dealer also sells special loudspeaker interconnecting cables and these are most often labelled with respect to polarity.

Generally speaking, when making connections to the loudspeakers from the amplifier, it is very important to use the correct type and size of wire in order to avoid unnecessary loss of amplifier power in the cable, reduction of amplifier damping factor (DF) and other undesirable conditions. For runs up to 12 feet, ordinary "zip" or lamp cord, made of AWG18 stranded wire and available in a variety of insulation colors may be used. For runs up to 40 feet, AWG16 stranded wire should be used to prevent power losses. For lengths over 40 feet and not exceeding 60 feet, use AWG14 stranded wire only. Runs exceeding 60 feet require the use of heavier conductors such as AWG12 stranded wire. If you find it difficult to obtain the correct-size wire for your specific connecting length, you can parallel two runs of the next smaller gauge of wire to keep wire resistance at a minimum. For example, if you require a run of 35 feet to your loudspeakers and AWG16 wire is not readily available, you can parallel two 35-foot lengths of AWG18 stranded wire for use with each speaker (you'll require a total of four 35-foot lengths in such an instance) and solder the two conductors of each wire making up each double cable, at both the speaker and amplifier ends, to insure good electrical and mechanical connections of the conductors.

Regardless of the cables you select to connect your loudspeakers, there are some other requirements which you should observe in order to insure maximum performance from your amplifier. It is most important that you make certain the wiring you have selected has as low a capacitance as possible. All amplifiers, particularly wide-bandwidth audio amplifiers, are susceptible to the capacitance cables present to their outputs at extremely high frequencies. This capacitance, in conjunction with the inductance of the wire itself and the reactive load of the loudspeakers, can create anomalies at ultrasonic frequencies which, although inaudible, can affect performance in the audible range.

There are different ways to connect the wiring to the RIGHT/LEFT STEREO SPEAKER OUTPUTS ②. The methods used will depend on the specific type of connectors supplied with the loudspeakers, the speaker cables, etc. As a matter of course, we prefer to use double banana plugs because it is generally the most secure method of connection. Also, the plated-bronze springs of the banana plugs effect a self-cleaning action which insures the best contacts between the binding posts and the connectors themselves. There are "sockets" provided in the center of the binding posts' studs which permit secure seating of the banana plugs. Make certain, however, that the hexagonal head of the binding post is securely tightened before inserting the banana plugs firmly into the binding posts' sockets.

Additionally, when connecting the cables to the amplifier and loudspeakers, it is important that you "tin" the wires with good solder (preferably high-silver-content solder) in order to minimize contact resistance. Tinning prevents the build-up of surface compounds which form with copper wire and which increase its contact resistance. It is partly for this reason that double or single banana plugs are preferred. However, make sure that the cable ends are tinned before you make the cable connections to the banana plugs. Alternatively, you can use "crimped" pins or other lugs to insure lowest contact resistance at the connection to the amplifier and loudspeakers.

If you prefer to use other methods of connection, unscrew the insulated, hexagonal head of the binding post until the hole in the binding-post stud is accessible. You can then insert the bare or tinned wire, or terminal pin, through the hole. You can also use the many varieties of spade lugs available by simply placing the tines of the spade lug onto the binding post stud. Turn the insulated hex head of the binding post clockwise until the wire or connector is firmly secured. Finger pressure is sufficient and you should not use pliers, or other tools, which could damage or over-tighten the binding post assembly. The binding post has been designed in such a way that finger pressure is all that is needed to cause a "pinching" action among the different metal surfaces to insure proper connection.

All loudspeaker systems having a nominal impedance down to 2 ohms can be connected to, and driven by, the GFA-555II. The GFA-555II can drive these low impedances at more than adequate power levels with no difficulty. It should be noted here that many loudspeaker systems which are rated, nominally, at 4 ohms drop in impedance, in some parts of their frequency range, to as low as 2 ohms (and some others to even less than 2 ohms). You will not experience difficulties even with these very-low-impedance loads.

In most applications, you can drive two or more sets of loudspeakers. You should note, however, that when loudspeakers are paralleled, the impedance presented to the amplifier is lower than the nominal impedance of each loudspeaker. In other words, if you parallel two 8-ohm sets of loudspeakers, the resultant impedance will be 4 ohms. If you parallel two sets of 4-ohm-impedance loudspeakers, the resultant impedance of the load will be 2 ohms. If 8-ohm and 4-ohm loudspeakers are paralleled, the resultant impedance will be about 2.6 ohms. In these last two situations, and depending on the lowest impedance of the nominally-4-ohm speakers, and when making excessive power demands from the amplifier, you may trigger the THERMAL PROTECTION ⑨ on the amplifier or blow one of the DC RAIL FUSES ③. See their respective sections for more information. In those very rare instances in which your particular application causes frequent activation of the THERMAL PROTECTION ⑨ circuitry, you might consider use of the FAN OPTION (q.v.) to increase amplifier cooling. Alternatively, and for convenient switching of multiple sets of speakers with impedance protection for the amplifier, you may consider the use of an ADCOM speaker selector. These are available from your ADCOM dealer.

Should you wish to verify that your loudspeakers are in-phase, once connections to the amplifier have been made, play a recording of solo voice with single-instrument accompaniment, at normal volume, with the preamplifier's mode switch in the mono or A+B position. Stand about three feet in front of the loudspeakers and exactly between them. If your loudspeakers are in-phase, the voice and accompanying instrument will appear to originate from a point directly in front of you and exact localization will be fairly easy. If you now move a foot or two to the left and the right of your previous position, the singer and instrumentalist will still appear to come from a point directly in front of you. If your loudspeakers are out-of-phase, the image of the performers will be imprecise and difficult to pinpoint. Depending on the room, the image may appear to be coming from behind you, or the sound will seem to surround you, and, as you move left and right from your center position, the origin of the sound will seem to change instantaneously.

Should your connections have resulted in an out-of-phase condition, simply reverse the leads on **one** of the loudspeakers; that is, switch the wire connected to the positive input terminal of the loudspeaker to the negative terminal of the loudspeaker and vice-versa. Repeat the listening test with the mono signal to make sure you are correct in your initial evaluation. If you can now achieve a precise and stable image of the singer and instrument between the two speakers, make that connection to the speaker permanent.

STEREO/BRIDGED MONO INPUT/OUTPUT ⑤

The GFA-555II can be used as a very powerful mono amplifier to drive 8-ohm or 4-ohm impedance loudspeakers when in its "bridged" mode. No modification to the amplifier is necessary for operation in the bridged mode, nor are any additional accessories required. However, you will need **two** GFA-555IIs for stereophonic reproduction, if you are using them in the bridged mono mode.

To set the amplifier in bridged mono operation, flip the STEREO/BRIDGED MONO INPUT ⑤ switch into the BRIDGED MONO INPUT position. When in the bridged mono mode, input to the amplifier is made **only** through the LEFT INPUT RCA jack. The connection to the RIGHT INPUT jack should be removed since the right-channel input portion of the amplifier is inoperative.

Only a single loudspeaker is to be connected to the GFA-555II when in the bridged mono mode. Please note that connections made to the loudspeaker from the GFA-555II, when used in the bridged mono mode, are different from those made when the amplifier is used in the stereo mode. The **LEFT RED** output binding-post terminal (labelled BRIDGED MONO OUTPUT "+") should be connected to the loudspeaker input terminal color-coded RED (or labelled POSITIVE, "+", POS, 8 OHMS or 4 OHMS). The **RIGHT RED** output binding post terminal on the amplifier (labelled BRIDGED MONO OUTPUT "-") should be connected to the BLACK loudspeaker terminal (or labelled NEG, "-", C, COM, COMMON, G, or GROUND). All the wiring and phasing recommendations in the section RIGHT/LEFT STEREO SPEAKER OUTPUT ② apply to this connection as well. Please note that if you want to insure correct stereo phasing with optimal bass response, you must observe these connections precisely.

Although the GFA-555II can generate a substantially greater amount of power in the bridged mono mode than when it is in its normal stereo mode, it requires the use of loudspeakers the nominal impedance of which does not drop below 4 ohms. It is not recommended that the GFA-555II be used in the bridged mono mode into loudspeakers, or multiple loudspeaker loads, which drop in value substantially below 4 ohms. Otherwise, you may trigger the THERMAL PROTECTION ⑨ or blow one of the DC RAIL FUSES ③. Please refer to the section RIGHT/LEFT STEREO SPEAKER OUTPUT ② for further clarification. A little known fact is that when any amplifier is operated in the bridged mode, the load is "split" between the two amplifiers in the bridged configuration. Therefore, an 8-ohm loudspeaker will be seen by the amplifier as if it were a 4-ohm load; a 4-ohm loudspeaker load will be seen by the amplifier as a 2-ohm load.

NOTE

If the connections described above are followed exactly, the GFA-555II will be polarity correct, that is, it will **not** invert "phase". Any positive-going signal at its input will appear as a positive-going signal at the loudspeaker.

DC RAIL FUSES ③

The DC RAIL FUSES provide protection for the output stages and power supply in the event of excessive current demands from the amplifier, either long-term or short-term.

If the amplifier ceases to operate, either on one or both channels, particularly during high-level passages, or long-term high-volume playback, and the POWER ⑦ LED glows while the THERMAL PROTECTION ⑨ LED is out, the chances are that one or both of the DC RAIL FUSES ③ on that channel, or both channels, are blown.

Your ADCOM amplifier is designed to activate its protective devices reliably, particularly when the amplifier is carelessly operated well beyond its limitations. Other types of protection circuits, beyond the methods used in the GFA-555II amplifier, such as current limiting, etc., usually result in deterioration of the audio performance of the amplifier.

While the GFA-555II will operate dependably in every normal situation, no amplifier is impervious to abuse. There are conditions which must always be avoided if the amplifier is to operate reliably and if triggering of protective devices is to be avoided. The preceding is particularly true of amplifiers which have extremely wide audio bandwidth, such as ADCOM amplifiers. Among the undertakings which must be avoided, if damage to the amplifier or to the loudspeakers being used is to be prevented, are actions such as connecting the inputs or outputs to or from the amplifier while the amplifier is **ON**; or using what has been commonly termed the "thumb test" — that is, touching the center pin of the RCA jack on one end of the audio interconnecting cable while the other end is plugged into the amplifier and the amplifier is **ON**.

NOTE

In the event that the DC RAIL FUSES need to be replaced, only one of the fuse types listed in the table below should be used. Please note that the fuses listed in the table, and their time-current blowing points, have been carefully selected and thoroughly tested to deliver optimal performance while still accomplishing their protective functions. Replace these fuses, individually, only with the specific types listed. **DO NOT USE ANY SUBSTITUTE FUSES WITH DIFFERENT RATINGS, TIME-CURRENT CURVES OR VALUES.** Failure to observe this precaution may cause serious damage to the amplifier circuits, **MAY CREATE A FIRE HAZARD, AND MAY VOID YOUR WARRANTY.** For your convenience, a replacement set of two of the correct DC RAIL FUSES is supplied with each amplifier to facilitate restoration of the amplifier to operation in the event of a blown fuse.

The GFA-555II has a massive power supply which remains charged for up to **FIVE MINUTES** after the amplifier is turned off and the POWER ⑦ LED ceases to glow. It also remains energized when the POWER ⑦ LED glows even if the THERMAL PROTECTION ⑨ LED is **ON**. Therefore, you should exercise great caution when connecting and/or disconnecting loudspeakers to or from the RIGHT/LEFT STEREO SPEAKER OUTPUTS ②. Should you inadvertently short out the RED ("+") and BLACK ("—") STEREO SPEAKER OUTPUTS ②, enough power may remain in the power supply to cause sufficient current to blow the DC RAIL FUSES ③ on the affected channel. When connecting or disconnecting loudspeakers to or from the RIGHT/LEFT STEREO SPEAKER OUTPUTS ②, always be certain to wait at least **FIVE MINUTES** after turning the amplifier **OFF** before undertaking any such procedure.

DC RAIL FUSES

BUSSMAN	AGC-7/250V
LITTELFUSE	3AG312007/250V
BEL	3AG 7A/125V

To remove a blown or suspect fuse from its fuse holder, use only a number 2 Phillips screwdriver to prevent damage to the fuse holder. Simply press lightly on the fuse-holder cap and turn counterclockwise. The cap will "pop" out after several turns. To replace the fuse-holder cap, once the fuse has been replaced and properly installed in its seat on the fuse-holder cap, press lightly inward, once the fuse and cap have been inserted in the fuse-holder body, and turn the cap clockwise until it is firmly seated in the fuse-holder body. Be certain not to cause cross-threading of the fuse-holder body and cap to prevent damaging the fuse holder. **DO NOT FORCE THE FUSE-HOLDER CAP INTO THE THREADS.** Seating of the cap in the fuse-holder body should be easily accomplished without excessive force.

AC LINE CORD ④

The AC cord is a 2-conductor, heavy-duty cable supplied with a heavy-duty, molded 2-prong AC plug. It provides the power to operate all the GFA-555II's circuits. Its plug should be inserted in a standard, 120V/60Hz outlet with a minimum capacity of 15 amperes and should have a dedicated branch circuit. It is not recommended that you connect the GFA-555II into a branch circuit on which other appliances are used. Since conventional household branch circuits are often limited to 15 amperes, when the GFA-555II is used in conjunction with other appliances on the circuit, you may find the current available for the GFA-555II is insufficient; particularly in systems using very low-impedance, highly reactive loudspeakers.

NOTE

The GFA-555II's power cord is supplied with a "polarized" AC plug as required by UL/CSA standards and the National Electrical Code. To minimize the risk of electrical shock, and to insure minimal hum from the system, do not defeat the polarity-insuring feature of the plug (one wide blade and one narrow blade). To prevent electrical shock, do not use the polarized plug with an extension cord or receptacle, or other outlet, unless the blades can be fully inserted to prevent blade exposure.

AC LINE FUSE ⑤

The AC LINE FUSE protects the electronic circuits of the GFA-555II. This fuse, normally, will blow only if there is an overload within the GFA-555II. Since this fuse has been designed to protect the electronic circuits in the GFA-555II, it is recommended that it be replaced only with one of the fuses listed in the table below. Please note that the fuses listed are for operation of the amplifier on 120VAC/60Hz. For the correct fuse values to operate the GFA-555II on other voltages and frequency, please consult the Service Manual for this amplifier available from the ADCOM Technical Service Department.

Whenever the POWER ⑥ switch on the front panel is turned on and the amplifier is energized, the POWER ⑦ LED will glow. If turning on the amplifier does not cause the POWER ⑦ LED to glow, it may be an indication that the AC LINE FUSE ⑤ is blown. Unplug the AC LINE CORD ④ from the AC wall outlet and turn the POWER ⑥ switch off and check the fuse. If the fuse is blown, replace it with one of the fuses listed in the table below, plug the amplifier into its AC-wall outlet and turn on the amplifier. If after replacing the fuse, it blows immediately upon turning on the amplifier (POWER ⑦ LED does not glow), a failed electronic component or other internal malfunction must be suspected. Make no further attempts at fuse replacement or operation of the amplifier. **Refer the problem to competent ADCOM-authorized service personnel.**

NOTE

Before checking or replacing a blown fuse, make certain you **UNPLUG THE AC LINE CORD ④ FROM THE AC WALL OUTLET TO PREVENT POSSIBLE ELECTRICAL SHOCK.**

AC LINE FUSES

BUSSMAN	ABC-12/250V
LITTELFUSE	3AB314012/250V
SOC	CES6-12A/125V

NOTE

The fuses listed above, and their time-current blowing points, have been carefully selected and thoroughly tested to deliver optimal performance while still accomplishing their protective functions. Replace the AC LINE FUSE only with one of the fuses listed above. **DO NOT USE ANY SUBSTITUTE FUSES WITH DIFFERENT RATINGS, TIME-CURRENT CURVES OR VALUES.** Failure to observe this precaution may cause serious damage to the amplifier circuits, **MAY CREATE A FIRE HAZARD, AND MAY VOID YOUR WARRANTY.**

To remove a blown or suspect fuse from its fuse holder, use only a number 2 Phillips screwdriver to prevent damage to the fuse holder. Simply press lightly on the fuse-holder cap and turn counterclockwise. The cap will “pop” out after several turns. To replace the fuse-holder cap, once the fuse has been replaced and properly installed in its seat on the fuse-holder cap, press lightly inward, once the fuse and cap have been inserted in the fuse-holder body, and turn the cap clockwise until it is firmly seated in the fuse-holder body. Be certain not to cause cross-threading of the fuse-holder body and cap to prevent damaging the fuse holder. **DO NOT FORCE THE FUSE-HOLDER CAP INTO THE THREADS.** Seating of the cap in the fuse-holder body should be easily accomplished without excessive force.

AC ON/OFF SWITCH ⑥

The AC ON/OFF switch ⑥ controls power to the power transformer and circuits of the GFA-555II. Whenever the GFA-555II is energized, the red POWER ⑦ LED will glow. Push the **top** of the rocker switch to energize the GFA-555II. Push the **bottom** of the rocker switch to turn the unit off.

POWER ⑦ LED

This LED will glow whenever the AC ON/OFF switch ⑥ is turned on and the GFA-555II is energized. If the AC LINE FUSE ⑤ blows, the POWER ⑦ LED will cease to glow.

The POWER ⑦ LED indicates that there is AC voltage being fed to the amplifier, but it does not signify that all the amplifier's circuits are in operation. If, for example, you have blown one or more of the DC RAIL FUSES ③, the amplifier will not operate — that is, the amplifier will not produce any audio signal — even though the POWER ⑦ LED glows. Similarly, if the THERMAL PROTECTION ⑨ LED glows, the amplifier will not produce sound even though the POWER ⑦ LED may still glow.

Additionally, the internal power transformer is provided with a thermostat which will interrupt power into the transformer if its temperature exceeds 125°C. This high a temperature will seldom, if ever, be encountered unless the amplifier is subjected to abnormal conditions, such as operation into loads of less than 1 ohm at very high listening levels, etc. If the POWER ⑦ LED does not glow, the THERMAL PROTECTION ⑧ LED is out and both the DC RAIL FUSES ③ and AC LINE FUSE ⑤ are intact, the indication would be that the thermostat within the transformer has opened.

Once the temperature within the transformer decreases to a normal level, the thermostat will reset itself and normal operation will resume. If you are to avoid tripping continually the thermostat in the transformer, you must reduce the sound level demands into such low impedances, install the FAN OPTION (q.v.) on the amplifier, or both.

For a more detailed description of the operation of the THERMAL PROTECTION ⑨ LED circuit and the DC RAIL FUSES ③, please refer to their respective sections.

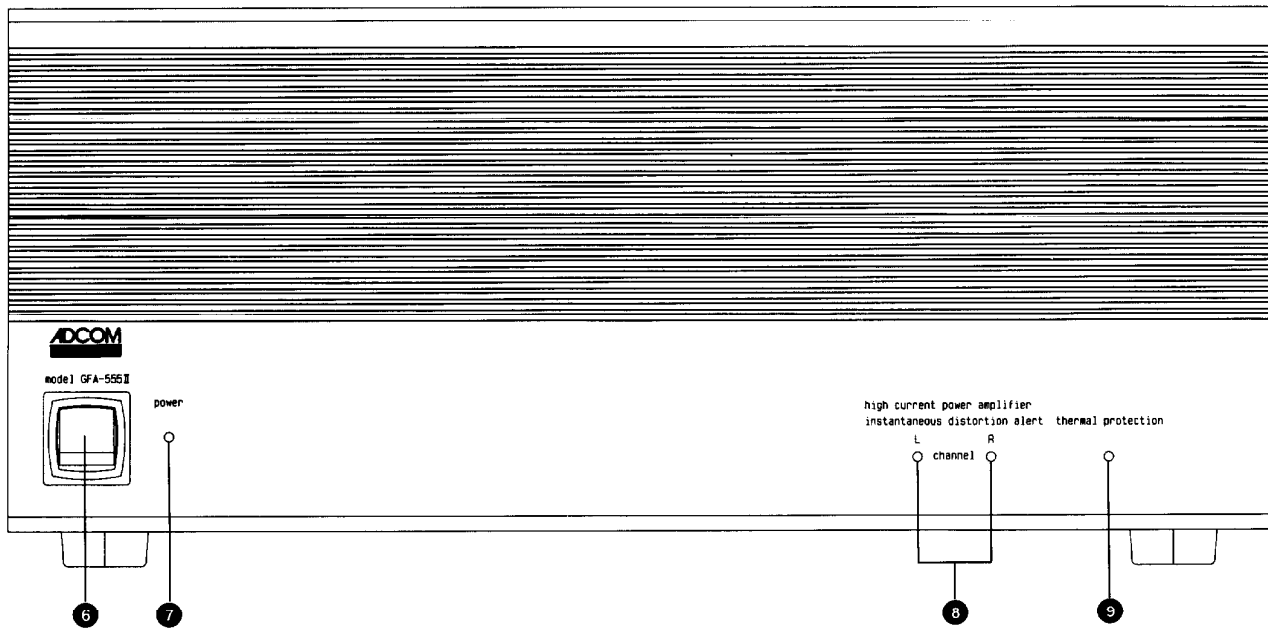

GFA-555II Front Panel Diagram

INSTANTANEOUS DISTORTION ALERT 8 LEDs

The INSTANTANEOUS DISTORTION ALERT circuit is a unique ADCOM distortion-detection system which reads all forms of non-linear distortion such as THD, IM, slew-induced, "clipping", etc. The INSTANTANEOUS DISTORTION ALERT 8 LEDs will light when distortion reaches 1% regardless of the impedance or the phase angle of the current/voltage and the reactance of the loudspeakers which the amplifier is driving. Sometimes, when the amplifier is in use, the LEDs may occasionally flicker under high-volume listening, particularly if you are driving low impedances. This flickering is no cause for concern. The LEDs are simply warning you that the amplifier is approaching its maximum power output into the specific loudspeakers which you are using. If, however, the INSTANTANEOUS DISTORTION ALERT LEDs glow brightly or are on most of the time during playback, you are overdriving the amplifier and should lower the volume control to reduce the listening-level demands, or you may blow the DC RAIL FUSES 3, cause the THERMAL PROTECTION 9 to be activated or, in extreme cases, damage your loudspeakers.

THERMAL PROTECTION 9 LED

The GFA-555II is provided with a thermal protection circuit which will shut down the amplifier if the temperature of either heatsink reaches 85°C. The THERMAL PROTECTION 9 LED will light whenever the thermal protection circuit on either channel, or both channels, has been triggered and the amplifier is inoperative. The thermal protection circuitry will typically be triggered by very high-power demands into impedances much lower than the amplifier is capable of driving at those levels. If the output of either channel of the amplifier ceases abruptly, and the THERMAL PROTECTION 9 LED glows, you will know that its heatsink temperature has become unacceptably high and the circuitry is protecting the amplification devices. Please note that the POWER 7 LED will remain on and the amplifier will still be energized.

Once the temperature of the heatsink(s) drops to a safe operating level, the amplifier will automatically return to operation.

If the amplifier ceases to operate and both the POWER 7 LED and the THERMAL PROTECTION 9 LED are off, the condition may indicate that the AC LINE FUSE 5 has blown. Please refer to the section AC LINE FUSE 5 for instructions on replacing this fuse.

NOTE

ACTIVATION OF THE THERMAL PROTECTION CIRCUITRY IN THE GFA-555II IS AN INDICATION THAT THE AMPLIFIER HAS BEEN OVERDRIVEN OR THAT THE LOAD THE LOUDSPEAKERS ARE PRESENTING TO THE AMPLIFIER IS UNREASONABLY LOW. IF YOU WISH TO PREVENT RECURRENT ACTIVATION OF THE THERMAL PROTECTION CIRCUITRY, YOU MUST REDUCE THE VOLUME LEVEL DEMANDS, RECTIFY THE LOAD-IMPEDANCE CONDITION WHICH MAY BE CAUSING ACTIVATION OF THIS CIRCUITRY, INSTALL THE FAN OPTION OR, IN EXTREME CASES, UNDERTAKE ALL THREE.

CARING FOR YOUR GFA-555II

Great care has been taken by ADCOM to assure that your amplifier is as flawless in appearance as it is electronically. The front panel is a heavy-gauge, high-grade aluminum extrusion carefully finished and anodized for durability. The chassis, top cover and rear panel are of heavy-gauge steel, both painted and baked. If the front panel, top or sides should become dusty or fingerprinted, they can be cleaned with a soft lintless cloth, slightly dampened with a very mild detergent solution or glass cleaner.

NOTE

DO NOT SPRAY OR USE LIQUIDS OF ANY KIND ON THE SURFACES OF THE GFA-555II. DO NOT EXPOSE THE AMPLIFIER TO RAIN, WATER OR MOISTURE OF ANY KIND.

SERVICING

ADCOM has a Technical Service Department to answer questions pertinent to the installation and operation of your unit. In the event of difficulty, please contact us for prompt advice. If your problem can not be resolved through our combined efforts, we may refer you to an authorized repair agency, or authorize return of the unit to our plant. To aid us in directing you to a convenient service station, it would be helpful if you indicate which major city is accessible to your home.

Please address mail inquiries to:
ADCOM Service Corp.
11 Elkins Road
East Brunswick, NJ 08816
U.S.A.

Phone or Fax inquiries:
Monday through Friday
9:00AM to 4:00PM Eastern Time
Phone Number: 908-390-1130
Fax Number: 908-390-9152

For fax inquiries, please include a return fax number for the reply.

When calling or writing about your GFA-555II, be sure to note and refer to its model and serial numbers as well as the date of purchase and the dealer from whom it was purchased. In the event the unit must be returned to our plant for service, you will be instructed as to the proper procedure when you call or write for a Return Authorization. **UNDER NO CIRCUMSTANCES SHOULD YOUR UNIT BE SHIPPED TO OUR PLANT WITHOUT PRIOR AUTHORIZATION, OR PACKED IN OTHER THAN ITS ORIGINAL CARTON AND FILLERS.**

If the original shipping carton and its fillers have been lost, discarded, or damaged, a duplicate carton may be obtained from our Service Department for a nominal charge. Inquire as to the procedure when requesting a Return Authorization.

Always ship PREPAID VIA UNITED PARCEL SERVICE (UPS) OR OTHER APPROVED CARRIER. DO NOT SHIP VIA PARCEL POST, since the packing was not designed to withstand rough Parcel Post handling. **FREIGHT COLLECT SHIPMENTS CANNOT BE ACCEPTED.**

GFA-555II SPECIFICATIONS

Power Rating (To FTC Requirements)

200 watts continuous average power into 8 ohms at any frequency between 20Hz and 20kHz with both channels driven at less than 0.04% THD.

325 watts continuous average power into 4 ohms at any frequency between 20Hz and 20kHz with both channels driven at less than 0.04% THD.*

600 watts continuous average power into 8 ohms at any frequency between 20Hz and 20kHz at less than 0.09% THD, bridged.*

* With FAN OPTION Installed.

IM Distortion (SMPTE)

1 watt to 200 watts into 8 ohms \leq 0.009%
 1 watt to 325 watts into 4 ohms \leq 0.009%

IM Distortion (CCIF, Any Combination from 4kHz to 20kHz)

200 watts into 8 ohms \leq 0.002%
 325 watts into 4 ohms \leq 0.003%

THD + Noise at 200 Watts into 8 Ohms

20Hz 0.004%
 1kHz 0.003%
 10kHz 0.006%
 20kHz 0.010%

THD + Noise at 325 Watts into 4 Ohms

20Hz 0.005%
 1kHz 0.004%
 10kHz 0.015%
 20kHz 0.025%

IM Distortion, Bridged (SMPTE)

1 watt to 600 watts into 8 ohms \leq 0.05%
 1 watt to 850 watts into 4 ohms \leq 0.05%

IM Distortion, Bridged (CCIF, Any Combination from 4kHz to 20kHz)

600 watts into 8 ohms \leq 0.005%
 850 watts into 4 ohms \leq 0.005%

THD + Noise at 600 Watts into 8 Ohms, Bridged

20Hz 0.004%
 1kHz 0.004%
 10kHz 0.02%
 20kHz 0.04%

THD + Noise at 850 Watts into 4 Ohms, Bridged

20Hz 0.01%
 1kHz 0.007%
 10kHz 0.05%
 20kHz 0.09%

Frequency Response @ 1 Watt into 8 Ohms

10Hz to 20kHz +0. —0.25dB

Power Bandwidth (—3dB)

1.7Hz to 100kHz

Dynamic Headroom into 4 Ohms

2.5dB

Signal-to-Noise Ratio, "A" Weighted

200 watts into 8 ohms \geq 110dB

Gain

27dB

Input Impedance

100,000 ohms

Input Sensitivity	
200 watts into 8 ohms	1.75V rms
1 watt into 8 ohms	130mV rms
Damping Factor	
20Hz to 20kHz	> 800
Rise Time	
5kHz, 120V peak-to-peak square wave, 20% to 80%	2.3us
Semiconductor Complement	
	42 transistors, 2 zener diodes, 13 diodes, 2 ICs, 2 diode bridges
Power Consumption (Continuous, Both Channels Driven)	
Quiescent	72VA
Maximum	1500VA
200 watts into 8 ohms	675VA
325 watts into 4 ohms	1180VA
600 watts into 8 ohms, bridged	1320VA

GENERAL

Power (available in 220V or 240V on special order)	120VAC/50-60Hz
Chassis Dimensions	6-3/4" (172mm) x 17" (432mm) x 12-3/16" (310mm)
Maximum Dimensions	7-1/4" (185mm) x 17" (432mm) x 12-3/16" (310mm)
Weight	35 lbs.(16kg)
Weight, Packed	39 lbs.(18kg)

Specifications subject to change without notice.

ADCOM®

11 Elkins Road
East Brunswick, NJ 08816
U.S.A.

Telephone (908) 390-1130
Fax (908) 390-9152

